



SAPPHIRE
CLEANROOMS

VACUUM CHAMBERS



VACUUM CHAMBERS

Sapphire Vacuum Chambers are designed for vacuum testing, degassing small parts, defoaming, mixed liquids, biological tests and storing samples under sustained low and intermediate vacuums.

- Removable cover
- Front Hinged Door
- Vacuum Gasket on Door Ensures Airtight Seal
- Supports Vacuum Level of 29.9" Hg
- Metering Valves
- Vacuum Gauge

MATERIALS

- Acrylic
- Aluminium
- Stainless Steel

Sapphire's complete line of environmental chambers includes test chambers, constant temperature and humidity chambers, laboratory incubators and vacuum chambers. Application-specific models meet the specialized demands of pharmaceutical drug efficacy testing, laboratory animal respiration studies, semiconductor hybrid package leak testing, and a host of other critical processes.

Some standard unit dimensions(inches): (ALL UNITS ARE CUSTOMIZABLE)

10 x 10 x 12	12 x 12 x 8	10 x 10 x 10	12 x 12 x 10	16 x 16 x 12	24 x 10 x 12
--------------	-------------	--------------	--------------	--------------	--------------

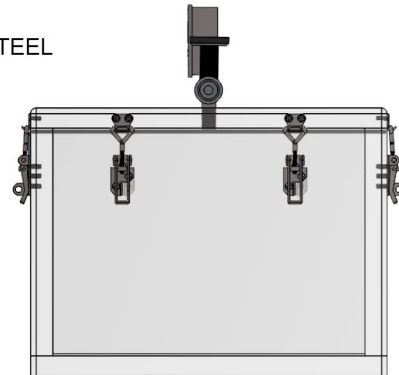
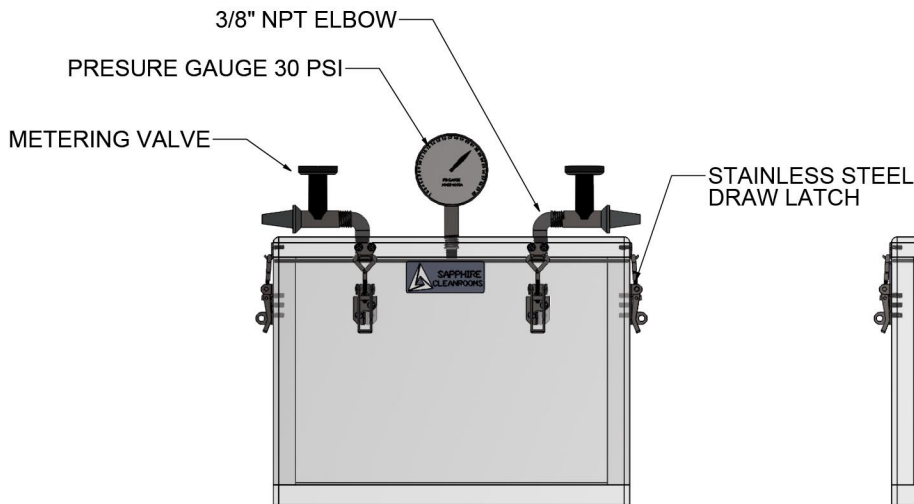
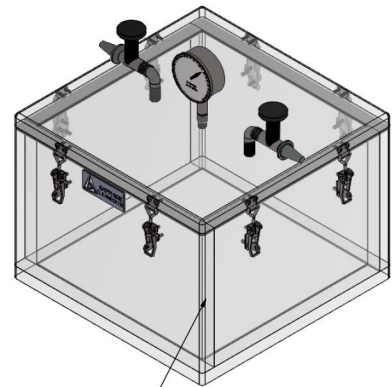
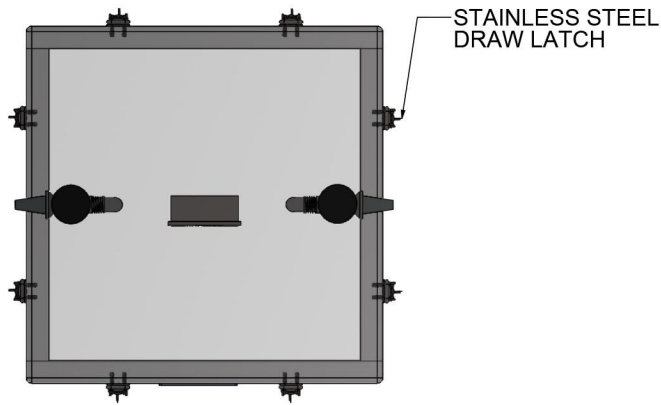

Standard:



Vacuum Gauge and Metering Valve

Highest quality valves and gauges ensure worry-free monitoring, bleeding and backfilling.



One-Inch Wall Thickness

1" thick acrylic walls will ensure a long service life and sustained vacuum of 29.9"Hg.



www.sapphirecleanrooms.com
sales@sapphirecleanrooms.com
(714) 316-5036